

OTTOMILA

Quick Installation Manual

EN IT DE FR ES CH

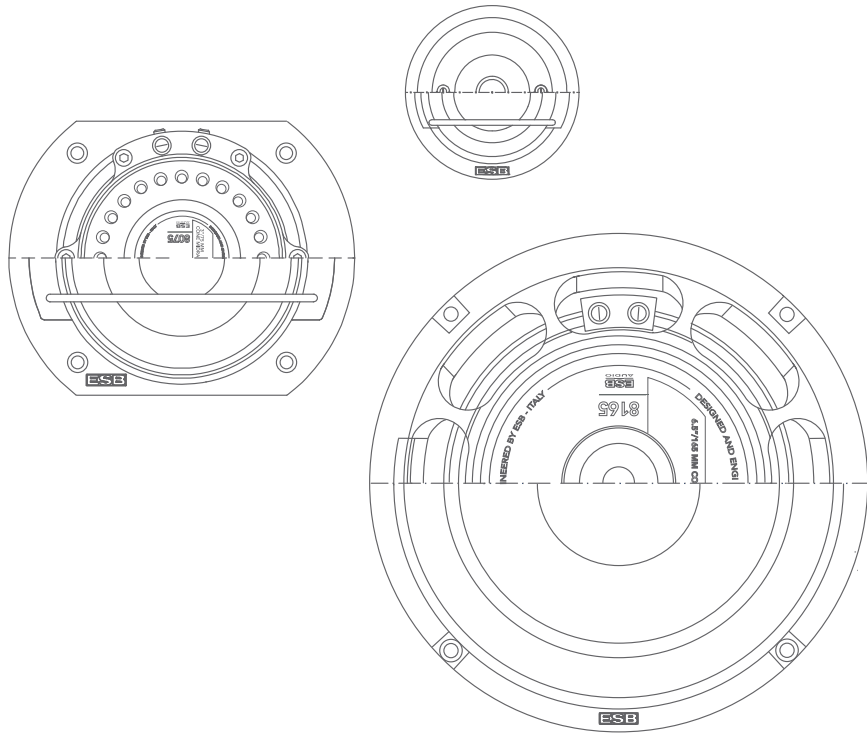

# 8000

---

High-End Speaker Series



8.028

Part List

- 1 2 x 8.028
- 2 2 x Fixing Ring

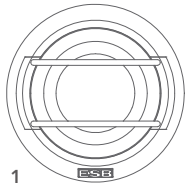

1

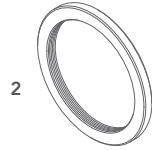

2

Installation

Option Mounting 1

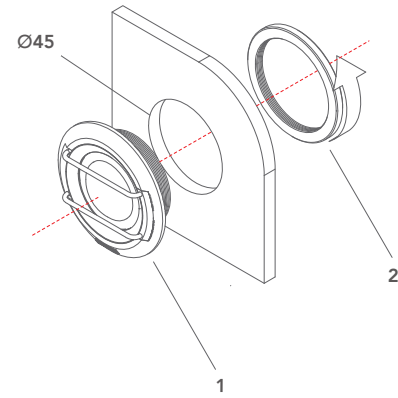

Option Mounting 2

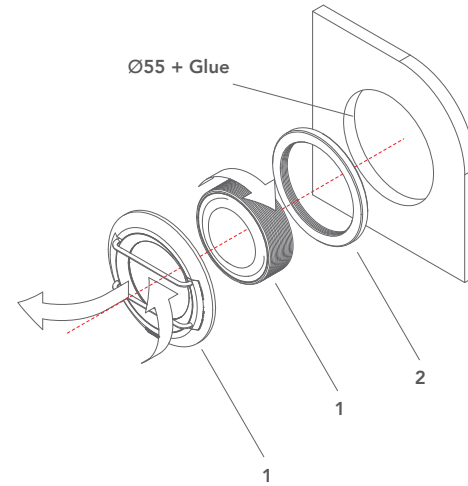

# 8.028S

## Part List

- 1 2 x 8.028S
- 2 2 x Fixing Ring
- 3 8 x Ø3x12 Screw
- 4 1 x Hallen L-Key

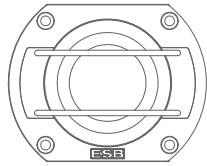

1



2



3

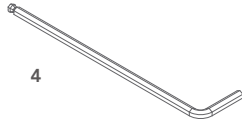

4

## Installation

### Option Mounting 1

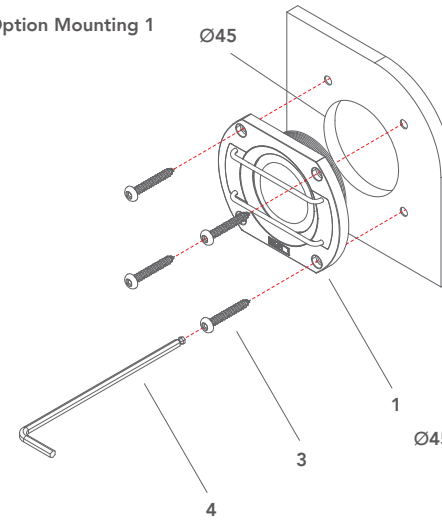

### Option Mounting 2

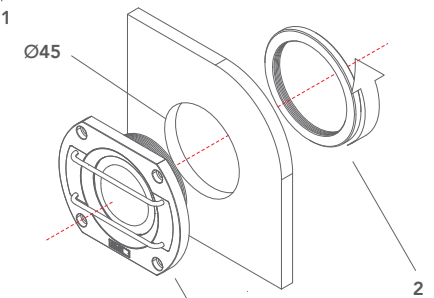

### Option Mounting 3

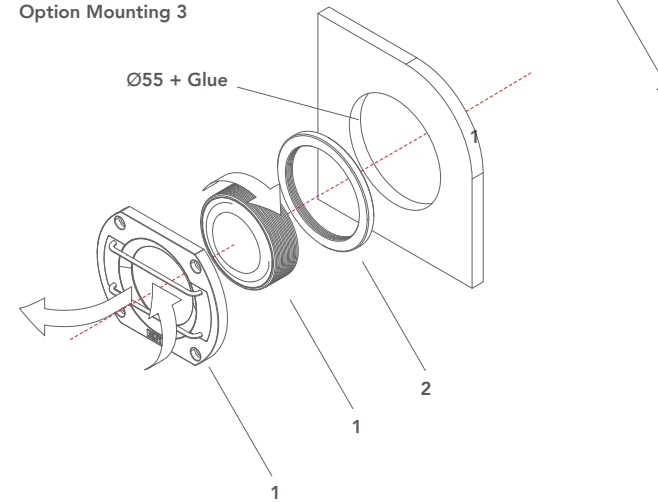

# 8.UMA

## Part List

- 1 2 x 8.003UMA
- 2 2 x Foam Gasket
- 3 8 x Ø3.5x16 Screw
- 4 1 x Hallen L-Key

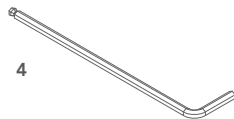
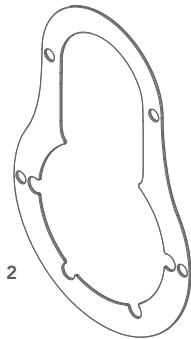
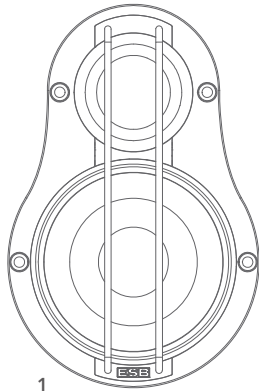

## Installation

### Hole Marking

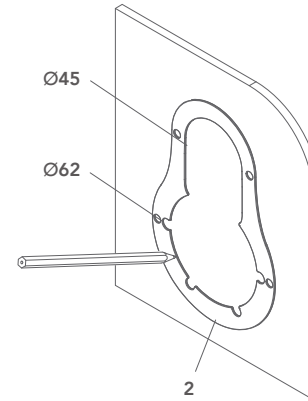

### Basic Mounting

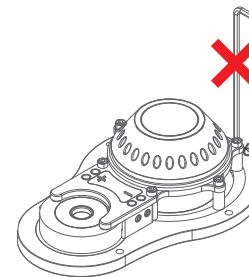
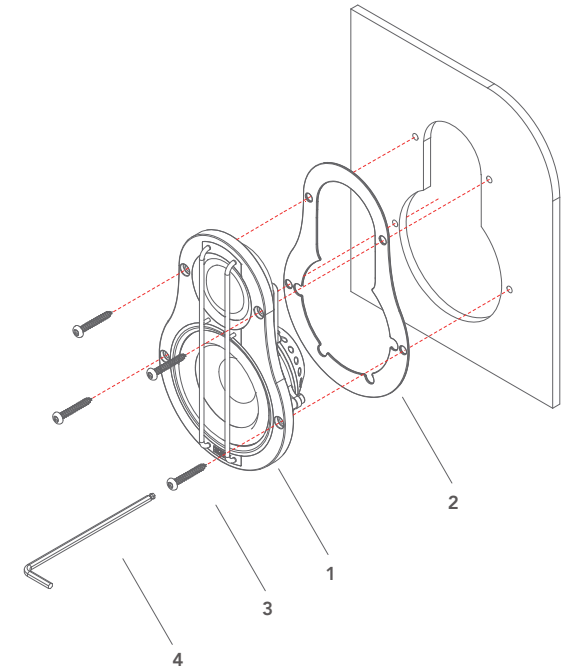

Peel min 4  
max 8 mm

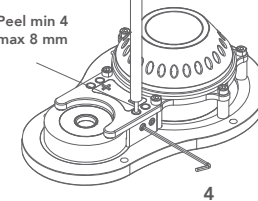

8.075

### Part List

- 1 2 x 8.075
- 2 2 x Foam Gasket
- 3 8 x Ø3.5x16 Screw
- 4 1 x Hallen L-Key

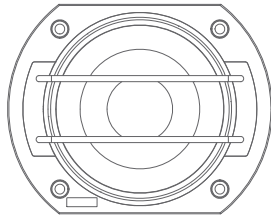

1

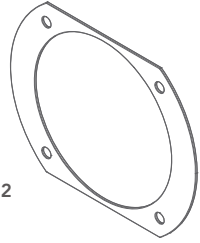

2



3

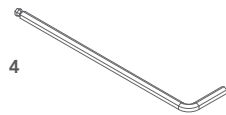

4

### Installation

Hole Marking

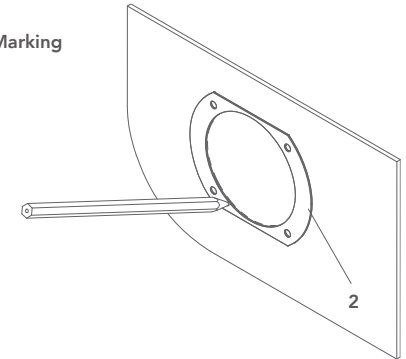

Basic Mounting

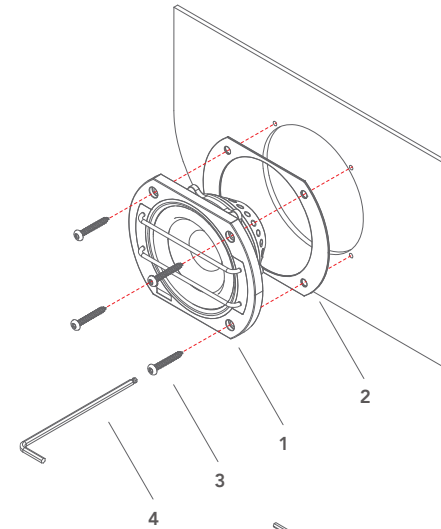

Midrange without Grille Mounting

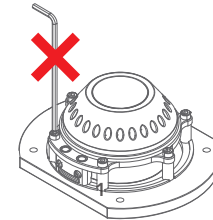

Peel min 4  
max 8 mm

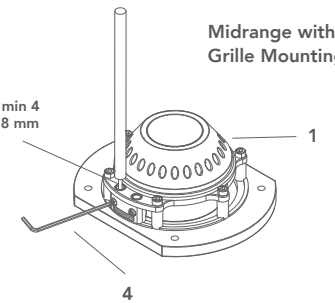

# 8.165

## Part List

- 1 2 x 8.165
- 2 2 x Foam Gasket
- 3 8 x Ø4x25 Screw
- 4 1 x Hallen L-Key

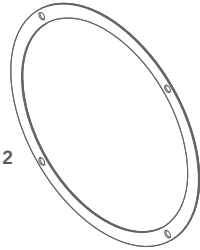
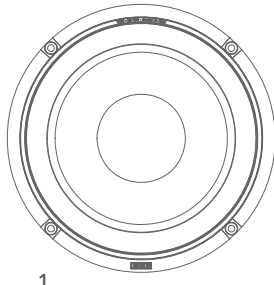

## Installation

Peel min 5  
max 10mm

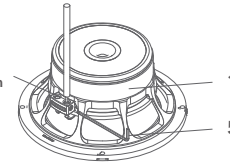

Hole Marking

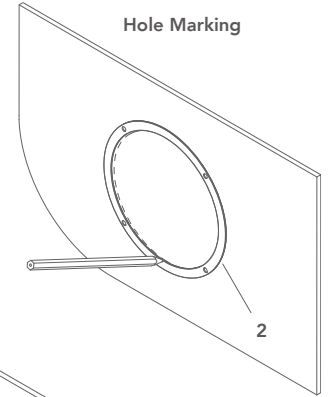

Woofer Mounting

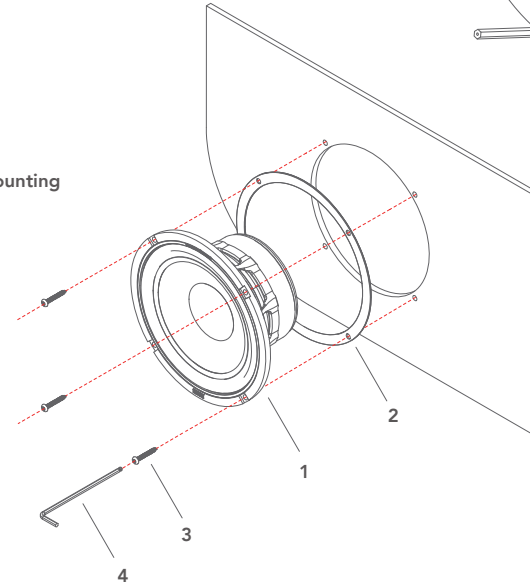



## 8.6K2 CX

The crossover network 8.6K2CX have been designed to allow tonal adjustments to the woofer and tweeter response, plus tweeter level. These adjustments make it possible to fine-tune your system to suit your listening preferences and to compensate different speaker mounting installation and orientation.

### Default Configuration (Bi-Amplification)

The inputs are splitted and two amplifiers are needed. One drives the bass frequency section (woofer), the second drives the high frequency section (tweeter). These amplifiers can be set in full range mode with electronic crossover. BIAMP + OFF: Without bi-amplification, the input to use is the woofer (IN-W) and the signal is distributed to the output of the two channels (woofer and tweeter). Only one amplifier is used to drive the whole channel at the same time.

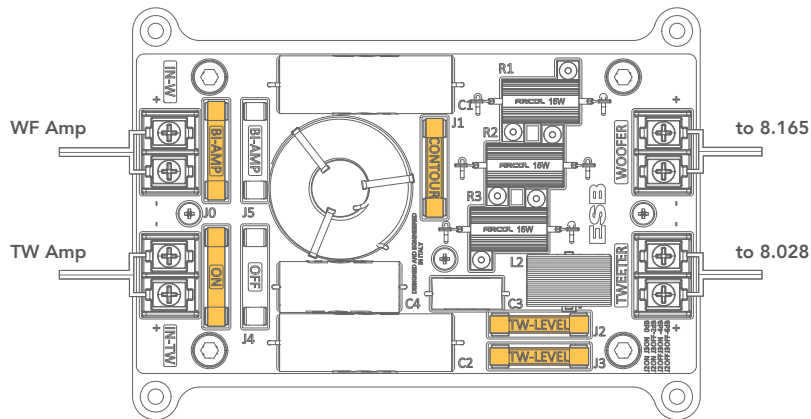

For **Woofer Contour** and **Tweeter Level Adjustments**, please refer to the Technical Data Sheet available on: [esbcar.com/support](http://esbcar.com/support)

## 8.6K3 CX

The crossover network 8.6K3CX have been designed to allow tonal adjustments to the woofer, mid, and tweeter response, plus mid, and tweeter level. These adjustments make it possible to fine-tune your system to suit your listening preferences and to compensate various speaker mounting installation and orientation.

### Default Configuration (Bi-Amplification)

The inputs are splitted and two amplifiers are needed. One drives the bass frequency section (woofer), the second drives the mid-high frequency section (midrange and tweeter). These amplifiers can be set in full range mode with electronic crossover. BIAMP + OFF: Without bi-amplification, the input to use is the woofer (IN-W) and the signal is distributed to the output of the two channels (woofer, midrange and tweeter). Only one amplifier is used to drive the whole channel at the same time.

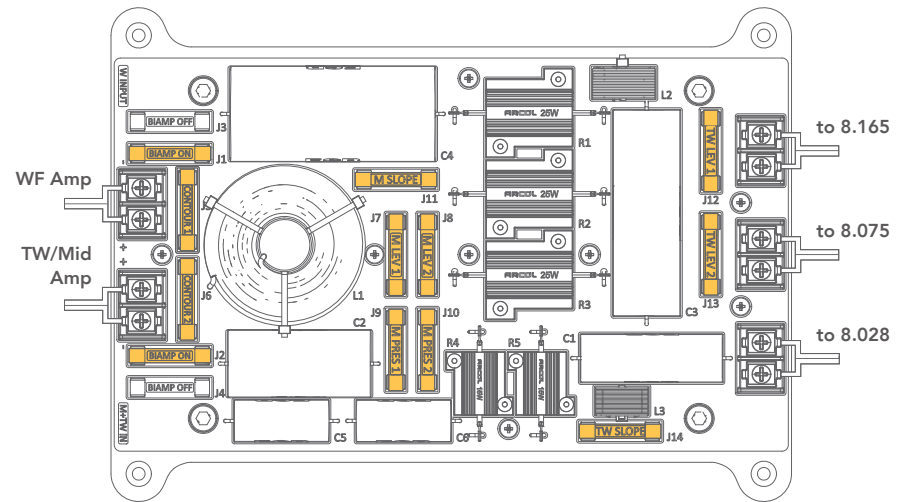

Midrange and Tweeter outputs can also be used with **8.003UMA** mid-high unit.  
For **Woofer Contour**, **Midrange Presence/Slope** and **Tweeter Slope/Level Adjustments**, please refer to the Technical Data Sheet available on: [esbcar.com/support](http://esbcar.com/support)

# Technical Specifications

## 8.028

Speaker Type: Component Tweeter  
Nominal Diameter: 1.1"/28 mm  
Nominal Impedance (Znom): 4 Ohms  
Continuous Power Handling: 110 W  
Peak Power Handling: 220 W  
Rec. Amplifier Power: 40 - 150W (RMS)

### Parameters

Voice Coil Resistance (Re): 3.4 Ohms  
Free Air Resonance (Fs): 540 Hz  
Sensitivity: 91.0 dB @ 1W/1m  
94.0 dB @ 2.83V/1m  
Electrical "Q" (Qes): 0.928  
Mechanical "Q" (Qms): 0.744  
Total Speaker "Q" (Qts): 0.413

## 8.028S

Speaker Type: Component Tweeter  
Nominal Diameter: 1.1"/28 mm  
Nominal Impedance (Znom): 4 Ohms  
Continuous Power Handling: 110 W  
Peak Power Handling: 220 W  
Rec. Amplifier Power: 40 - 150W (RMS)

### Parameters

Voice Coil Resistance (Re): 3.4 Ohms  
Free Air Resonance (Fs): 540 Hz  
Sensitivity: 91.0 dB @ 1W/1m  
94.0 dB @ 2.83V/1m  
Electrical "Q" (Qes): 0.928  
Mechanical "Q" (Qms): 0.744  
Total Speaker "Q" (Qts): 0.413

## 8.003UMA

Speaker Type: Component Tweeter  
Nominal Diameter: 1.1"/28 mm  
Nominal Impedance (Znom): 4 Ohms  
Continuous Power Handling: 110 W  
Peak Power Handling: 220 W  
Rec. Amplifier Power: 40 - 150W (RMS)

### Parameters

Voice Coil Resistance (Re): 3.4 Ohms  
Free Air Resonance (Fs): 540 Hz  
Sensitivity: 91.0 dB @ 1W/1m  
94.0 dB @ 2.83V/1m  
Electrical "Q" (Qes): 0.928  
Mechanical "Q" (Qms): 0.744  
Total Speaker "Q" (Qts): 0.413

Speaker Type: Component Midrange  
Nominal Diameter: 3"/75 mm  
Nominal Impedance (Znom): 4 Ohms  
Continuous Power Handling: 120 W  
Peak Power Handling: 240 W  
Rec. Amplifier Power: 50 - 160W (RMS)

### Parameters

Voice Coil Resistance (Re): 3.3 Ohms  
Free Air Resonance (Fs): 113 Hz  
Reference Efficiency (no): 0.25 %  
Sensitivity: 91 dB @ 1W/1m  
94 dB @ 2.83V/1m  
Electrical "Q" (Qes): 0.42  
Mechanical "Q" (Qms): 4.76  
Total Speaker "Q" (Qts): 0.39  
Equivalent Compliance (Vas): 0.95 lt  
Moving Mass (Mms): 2.45 g  
Mech. Compliance (Cms): 0.8 m/N  
Magnetic Strength (BL): 3.83 N/A  
Effective Piston Area (Sd): 29 sq. cm.  
One-Way Linear Excursion (Xmax): 5.7 mm

## 8.075

Speaker Type: Component Midrange  
Nominal Diameter: 3"/75 mm  
Nominal Impedance (Znom): 4 Ohms  
Continuous Power Handling: 120 W  
Peak Power Handling: 240 W  
Rec. Amplifier Power: 50 - 160W (RMS)

### Parameters

Voice Coil Resistance (Re): 3.3 Ohms  
Free Air Resonance (Fs): 113 Hz  
Reference Efficiency (no): 0.25 %  
Sensitivity: 91 dB @ 1W/1m  
94 dB @ 2.83V/1m  
Electrical "Q" (Qes): 0.42  
Mechanical "Q" (Qms): 4.76  
Total Speaker "Q" (Qts): 0.39  
Equivalent Compliance (Vas): 0.95 lt  
Moving Mass (Mms): 2.45 g  
Mech. Compliance (Cms): 0.8 m/N  
Magnetic Strength (BL): 3.83 N/A  
Effective Piston Area (Sd): 29 sq. cm.  
One-Way Linear Excursion (Xmax): 5.7 mm

## 8.165

Speaker Type: Component Mid-Woofers  
Nominal Diameter: 6.5"/165 mm  
Nominal Impedance (Znom): 3 Ohms  
Continuous Power Handling: 160 W  
Peak Power Handling: 320 W  
Rec. Amplifier Power: 60 - 280W (RMS)

### Parameters

Voice Coil Resistance (Re): 2.2 Ohms  
Free Air Resonance (Fs): 62.7 Hz  
Reference Efficiency (no): 0.57 %  
Sensitivity: 89 dB @ 1W/1m  
92 dB @ 2.83V/1m  
Electrical "Q" (Qes): 0.43  
Mechanical "Q" (Qms): 4.27  
Total Speaker "Q" (Qts): 0.39  
Equivalent Compliance (Vas): 11.1 lt  
Moving Mass (Mms): 13.5 g  
Mech. Compliance (Cms): 0.475 m/N  
Magnetic Strength (BL): 5.20 N/A  
Effective Piston Area (Sd): 130 sq. cm.  
One-Way Linear Excursion (Xmax): 14.6 mm

## 8.6K2 CX

Crossover Type: Passive 2-Way  
Tweeter Attenuation Levels: 0; -2; -4; -6 dB  
2 Levels of Adjustment for the Woofer  
and Tweeter Transition Zone

## 8.6K3 CX

Crossover Type: Passive 3-Way  
Tweeter Attenuation Levels: 0; -2; -4; -6 dB  
Midrange Attenuation Levels: 0; -3; -6; -9 dB  
3 Midrange High Pass Frequencies  
2 Different Cutting Slopes for the Tweeter  
and Midrange.  
4 Levels of Adjustment for the Woofer  
and Midrange Transition Zone



**Designed and Engineered in Italy by ESB**

Distributed in Europe / Distribuito in Europa da:  
ARPA of Europe srl - Via Isonzo snc, 04100 Latina, Italia

**esbcar.com**

Manual v.1.1 - May 23, 2024

**ESB**  
AUDIO