

- 4-layers dual voice coil
- Kapton® voice coil support
- High grade Y30 magnet
- Motor made of very low carbon steel
- Optimized motor design
- Long travel rubber surround
- Steel basket
- Internal stiffening ring
- Treated cellulose pulp cone
- Conex® spider
- CNC plates processing



Your ESB subwoofer is a precision loudspeaker which has been designed to produce very high-quality sub-bass frequency performance in your car. For maximize the performance of your speaker we highly recommend to use a dedicated enclosure. Inside this manual you will find specifications and two recommended enclosures for your speaker: one is a sealed enclosure, the other is a ported design. Both types of enclosures will give you excellent sound quality and low-frequency extension. The sealed enclosure is a better choice if space is extremely tight, but the ported enclosure will produce 3dB more output at the same power if you have the extra space to work with.

T&S parameters specification

Free air resonance (Fs):	36.6 Hz
Electrical "Q" (Qes):	0.51
Mechanical "Q" (Qms):	2.13
Total speaker "Q" (Qts):	0.42
Equivalent Compliance (Vas):	0.808 ft ³ / 22.8 lit.
Linear Excursion (Xmax):	0.551" / 14 mm
Efficiency (1W/1m):	85.3 dB SPL
Effective piston area (Sd):	0.558 in ³ / 359,68 mm ²
DC resistance* (Re):	1.79 + 1.79 Ohm
Nominal impedance:	2+2 Ohm
Power handling (continuous):	490 W
Power handling (peak)	980 W

*Series and parallel value

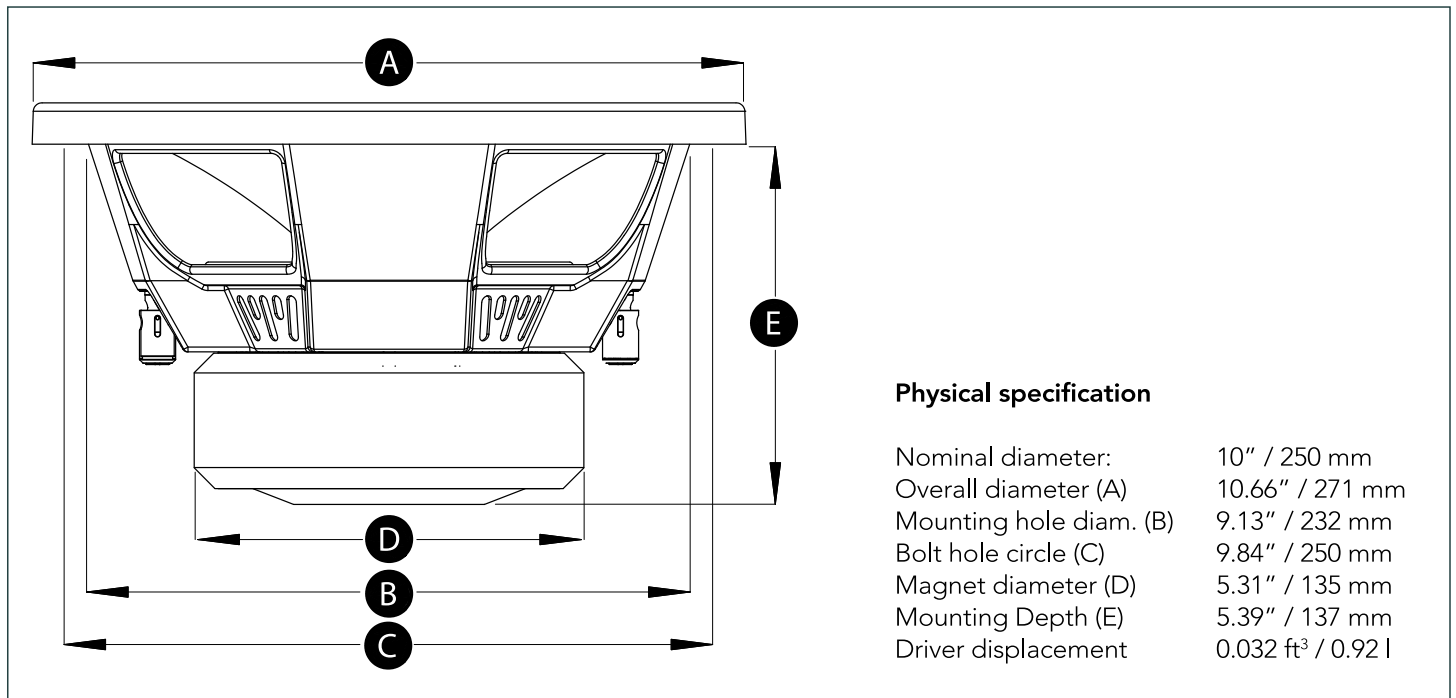

Physical specification

Nominal diameter:	10" / 250 mm
Overall diameter (A)	10.66" / 271 mm
Mounting hole diam. (B)	9.13" / 232 mm
Bolt hole circle (C)	9.84" / 250 mm
Magnet diameter (D)	5.31" / 135 mm
Mounting Depth (E)	5.39" / 137 mm
Driver displacement	0.032 ft ³ / 0.92 l

